

# Installation Instructions for Type J Power Roof Ventilators

OPERATION AND MAINTENANCE INSTRUCTIONS — OTHER SIDE

**1. Pre-Installation Check of PRV.** Before installation of an American Coolair PRV, a careful check should be made for shipping damage which may affect operation of the unit. Concealed damage to the wind shroud-damper assembly and base is a possibility. If damage is found, file a claim immediately with delivering carrier. On belt drive units, pulley alignment and belt tension should be checked (see paragraph 3 under Operation and Maintenance). Before connecting to power source, make sure propeller turns freely without striking orifice or any foreign object. Check motor nameplate to be sure correct phase, voltage and motor connection are being used. Note direction arrow on orifice for correct propeller rotation when power is applied.

**2. Installation Procedures.** The Type J PRV is shipped in two packages for quick assembly and installation on roof curb.

(a) **Installation of Base of PRV.** The major component of the Type J PRV is the base which contains curb cap, propeller and motor. Verify curb dimensions and securely attach base to curb.

(b) **Installation of Wind Shroud Assembly.** The wind shroud assembly consists of wind shroud and counterbalanced dampers. Wind shroud assembly should be attached to shroud supports on base of PRV. Bolts for this purpose are in a bag tied to the damper stop inside the wind shroud. To position wind shroud for attachment, two short pieces of 2 × 4 can be used. Lay the pieces of wood on the curb cap to temporarily support wind shroud. Metal clips holding dampers in closed position for shipment should be removed and discarded. Manually operate dampers to be sure they open freely and close snugly over inner ring of shroud.

(c) **Magnetic Latches (Optional Accessory).** If magnetic latches are provided, check adjustment of latches to insure proper contact with dampers when closed.

(d) **Automatic Heat and Smoke Venting (Optional Accessory).** If a heat and smoke venting device is included, actuator arms are held in horizontal position by fusible links. This mechanism is factory set and should require no adjustment.

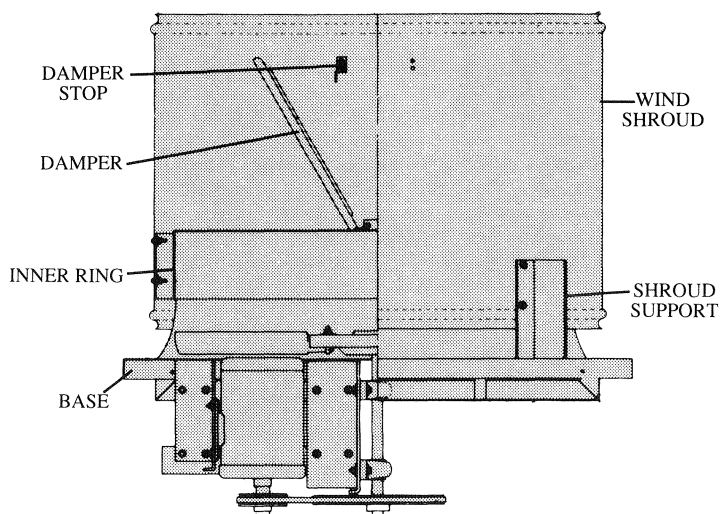

TYPE JBC PRV  
(Cutaway View)

**NOTE:** All local, state and federal codes should be checked to make sure all wiring, guarding and intended usage of the PRV unit(s) comply with all applicable codes. The proper type and class of PRV and motor should be used for air being handled such as explosive or other hazardous air mixtures.

WARNING	CAUTION
	<b>DO NOT</b> INSTALL FAN WITH MOVING PARTS WITHIN 8 FEET OF FLOOR OR GRADE LEVEL WITHOUT A GUARD THAT COMPLIES WITH OSHA REGULATIONS. <b>DO NOT</b> USE UNLESS ELECTRICAL WIRING COMPLIES WITH ALL APPLICABLE CODES. <b>DO NOT</b> WIRE WITHOUT PROVIDING FOR A POWER SOURCE DISCONNECT AT THE FAN ITSELF. <b>DO NOT</b> SERVICE EXCEPT BY A QUALIFIED MAINTENANCE TECHNICIAN AND ONLY AFTER DISCONNECTING THE POWER SOURCE. FAILURE TO OBSERVE THESE PRECAUTIONS CAN RESULT IN SERIOUS INJURY OR DEATH.

**AMERICAN**  
**Coolair**®

P.O. Box 2300 Jacksonville, Florida 32203  
Phone (904) 389-3646  
FAX (904) 387-3449

# Operation and Maintenance Instructions for Type J Power Roof Ventilators

INSTALLATION INSTRUCTIONS — OTHER SIDE

1. **Cleaning and Adjustment.** The entire PRV should be cleaned as necessary to remove accumulated dust, grease or other foreign matter which may collect on the blades or other parts. On belt drive models, belts should be inspected and tension adjusted (see below). Check for belt misalignment which will cause excessive wear and premature failure. This same inspection of belts and adjustment of tension should be made frequently during the first 24–48 hours of operation following installation. If rust or corrosion are found anywhere on the PRV, the affected area should be thoroughly cleaned and refinished.

2. **PRV Style.** Type J PRVs are divided into several “styles.” It may be important for you to know which style you have. Check the model number on the PRV. The letter preceding the size number is the style of that PRV. Example: Model JBH42P is Style H, 42” size.

3. **Belt Replacement, Tension and Adjustment (Belt drive only).**

(a) For convenience in roof top servicing, remove wind shroud from base of unit. On Style H, easy access to the propeller, belts and motor is then available. On Styles C and Y belt change from underneath the unit may be necessary. However, belt adjustment can be performed from the roof top.

(b) To install new belt(s), loosen motor bracket bolts and tension adjustment bolts and remove old belt(s) from motor pulley and fan pulley. On Style H, thread old belt over the end of blades on propeller. Thread new belt on to propeller by reversing the procedure. Loosening bolts holding shaft to X-brace makes this easier. When replacing belts, do not roll new belts over pulleys under tension. This practice can damage belts severely.

(c) Position new belt(s) on fan pulley and motor pulley. Adjust belt tension and retighten motor bracket bolts (see paragraph (d) below). Check belt alignment between motor pulley and fan pulley.

(d) To check belt tension, place a finger midway between fan pulley and motor pulley and push belt(s) inward about 1/2” (at approximately 5 lb. force) for proper tension. To adjust tension on Styles H, C and Y, loosen motor bracket bolts and utilize Tension Adjustment Bolts to obtain correct belt tension. Retighten all motor bracket bolts to maintain correct tension. Recheck alignment of belts, between motor pulley and fan pulley. **CAUTION:** Use of tension adjustment bolts makes it easy to overtighten belts. When this occurs belts will soon fail. **DO NOT OVERTENSION.**

4. **Blade Pitch Adjustment.** On Style C (both direct and belt drive), the propeller has blades on which the pitch may be adjusted. The blade pitch on standard models is factory set for specified performance. As any change in blade pitch will affect motor load, contact your American Coolair representative for instructions before making any field adjustment of blade pitch. **DO NOT ATTEMPT TO CHANGE BLADE PITCH WITHOUT INSTRUCTIONS.**

5. **Lubrication.** On all belt drive models, fan bearings are factory lubricated for extended service. On Style H fans relubrication as a part of regular maintenance is not necessary and lubrication fittings are not provided. On Styles C and Y, pillow block type bearings are used with Zerk fittings. Relubrication annually or more frequently is recommended. For best results, use Shell Alvania No. 3 lubricant or equivalent. For lubrication of electric motors, see instructions supplied by motor manufacturer.

6. **Repair Parts.**

(a) **Belts** — Belts are standard V-belts used on industrial machines and replacements may be obtained through local industrial supply houses. If more than one belt is used on the fan, be sure to replace with matched sets. To install belts, see instructions above for belt replacement.

(b) **Blades** — If one or more blades on propeller are damaged, it is recommended that entire blade assembly be removed and returned to the Factory for necessary repair and rebalancing. On Style H, remove shaft from X-brace on fan frame and return the complete propeller, bearing assembly and shaft. For convenience in shipment, individual blades may be removed from the wheel. On Styles C and Y, remove propeller from the motor or drive shaft.

(c) **Bearings** — Field replacement of bearings on Style H models is not recommended. Disassemble and return entire blade assembly to the factory for repairs. Pillow block bearings on Styles C and Y may be replaced in the field.

(d) **Motor** — Motor repairs should be performed only by an authorized motor repair station. Contact the motor manufacturer or American Coolair for location of repair station.

**CAUTION:** Do not return damaged or defective parts to American Coolair without prior authorization. If repairs under warranty are claimed, see warranty terms in American Coolair Catalog or contact the factory at Jacksonville, Florida. Claims for warranty repairs to electric motor should be made direct to the motor manufacturer.

**AMERICAN**  
**Coolair**®

P.O. Box 2300 Jacksonville, Florida 32203  
Phone (904) 389-3646  
FAX (904) 387-3449