

# Type PT– Power Tube Fan Make-Up Air System

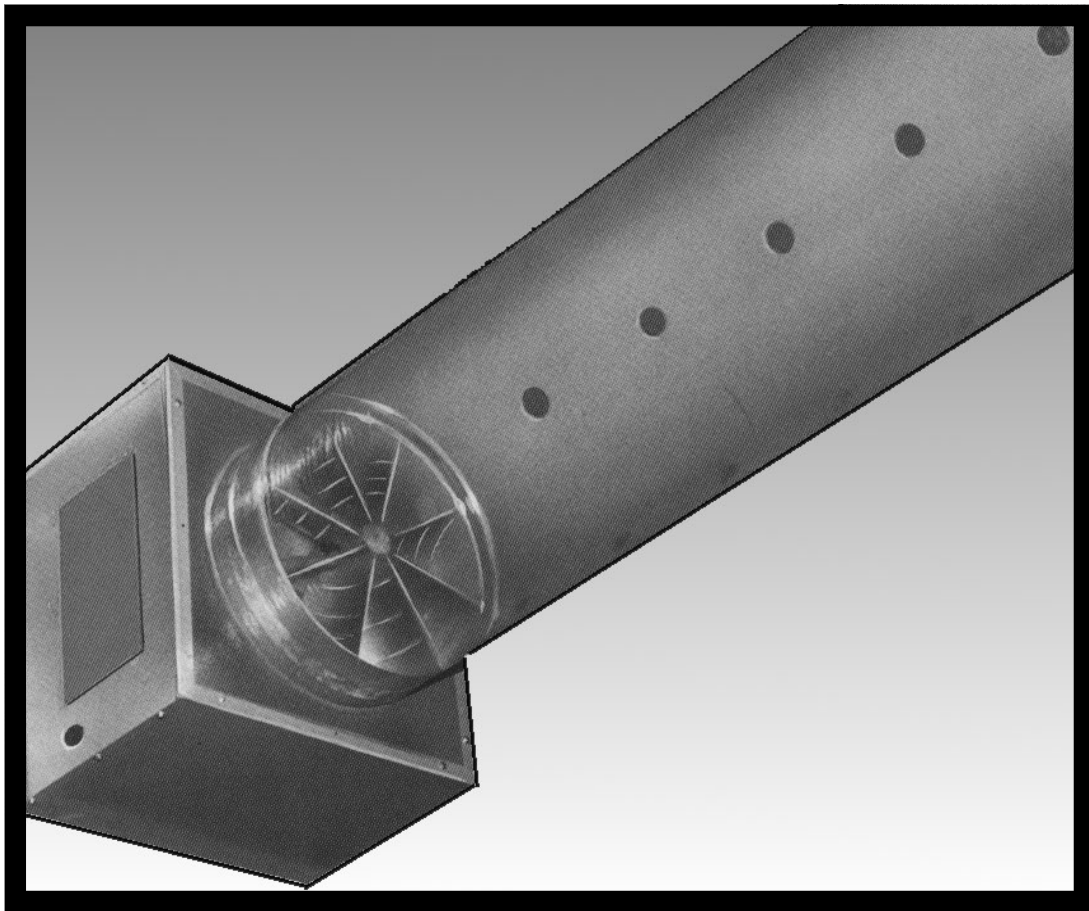

# Type PT-Power Tube Fan Make-Up Air System

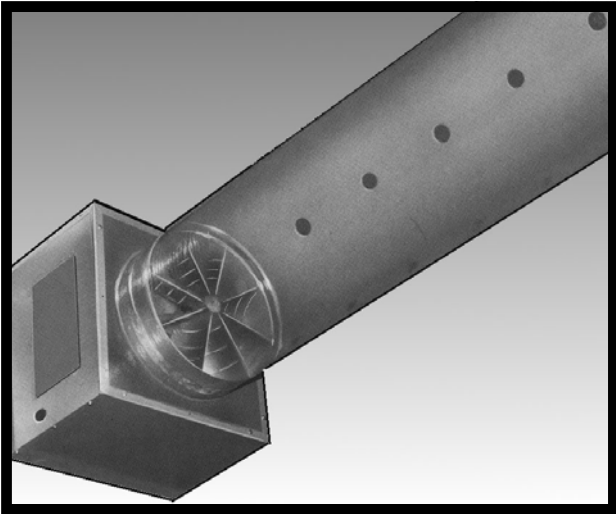

## Saves money by reclaiming wasted building heat

All make-up air systems use outside air to “make-up” for the exhausted air that creates the negative air pressure problem. In the winter, conventional make-up air systems have to heat the cold outside air prior to introduction into the building. This is an expensive process in both equipment and continuing energy cost.

But the American Coolair Power Tube Fan Make-Up Air System is different. It is a simpler system that utilizes wasted building heat and basic aerodynamic principles for supplying, tempering and distributing make-up air.

And that makes it less expensive than conventional make-up air systems to purchase, to install and to operate.

## Type PT Fans

- Application..... 2
- Type PT Fans-General Information..... 2
- PT Dimensional Data..... 3
- PT Performance..... Back cover
- Accessories ..... Back cover
- Warranty and Caution..... Back cover

## Solves problems by providing make-up air

When exhaust fans are used to provide ventilation, both for industrial and process exhaust and personnel comfort, a negative air pressure is created within the building.

This negative pressure causes several problems.

Process exhaust systems are less efficient and may not work properly.

Down flow can occur through gravity vents and result in the back venting of products of combustion from flues and stacks of heaters and process equipment.

Drafts are created that are a discomfort to employees. Safe opening of outside doors may even be impaired. The American Coolair Power Tube Fan Make-Up Air System solves all of these problems economically, even on the coldest winter day.

## Here’s how it works

The American Coolair Power Tube Fan Make-Up Air System uses a special propeller fan with air straightening vanes and fan housing mounted to an opening in a building sidewall near the ceiling (an optional roof mounting model is available). A motor operated wall shutter is attached to the outside wall opening under a protective weather hood. A long specially constructed reinforced polyethylene tube is connected to the fan discharge orifice to carry fresh outside air throughout the building and temper it by mixing cold outside air with warm inside air near the plant ceiling before it reaches floor level.

Specially sized and spaced discharge holes in the polyethylene tube produce relatively high velocity turbulent jets of air. This turbulent jet flow swirls and mixes surrounding air particles resulting in the entrainment of the warm ceiling air and the complete tempering of very cold outside air within a relatively short distance.

The result is heated make-up air at the price of unheated make-up air.

### BEFORE

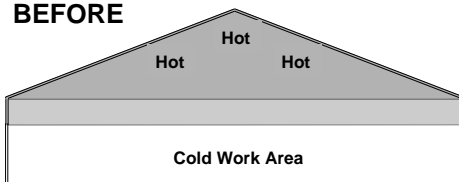

Unused heat is naturally trapped in the upper regions of buildings. The Coolair system tempers cold make-up air by mixing it with the warm overhead air that is normally wasted.

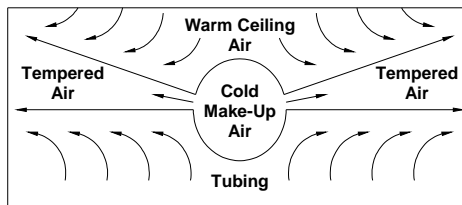

Turbulent jet flow results in completely mixed air within a short distance from the tube.

### AFTER

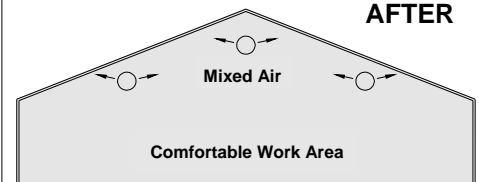

**Consider the cost of heating make-up air**

The following formula can be used to estimate the yearly heating requirements and the yearly cost of heating make-up air.

It is based on typical heating equipment (either gas- or oil-fired) with an efficiency of 80%, and an eight hour work (heating) shift.

With the yearly heating requirement and the local

$$YHR = 10.85 \times HD \times Q \times \Delta T \times WS$$

Where YHR = Yearly heating requirement during heating season in BTU per year.  
 HD = Heating days per year.  
 Q = CFM of heated air required.  
 ΔT = Temperature rise of outside air to design inside air temperature requirement (inside air temperature design minus outside average temperature).  
 WS = Number of eight hour shifts worked per day.

fuel rate know, a yearly heating cost can be estimated using the following formula.

EXAMPLE: A plant operation in Milwaukee, Wisconsin, has a requirement for 27,500 CFM of

$$YHC = YHR \div HV \times FR$$

Where YHC = Yearly heating cost during heating season.  
 YHR = Yearly heating requirement (BTU/YR).  
 HV = Heating value of fuel being used.  
 Typical HV of two common fuels are:  
 1. Natural Gas = 1025 BTU/FT<sup>3</sup>  
 2. Heating Oil = 140,000 BTU/GAL  
 FR = Local fuel rate for space heating equipment.

heated make-up air to a design inside air temperature of 70°F, and the work shift is two eight-hour shifts per day. Use 33°F average winter temperature, 174 heating days per year. The fuel cost is \$1.25 per gallon of heating oil.

**Calculations:  
Consider the dramatic ROI of an American Coolair System**

$$YHR = 10.85 \times HD \times Q \times \Delta T \times WS$$

$$= 10.85 \times 174 \times 27,500 \times 37 \times 2$$

$$= 3,841,876,500 \text{ BTU/YR}$$

With heating oil:  
 $YHC = YHR \div HV \times FR$   
 $YHC = \frac{3,841,876,500}{140,000} \times \$1.25$   
 $YHC = \$34,302$

The American Coolair Power Tube Fan System eliminates the cost of heating make-up air. Depending on your location, the savings in fuel alone can be substantial.

Plus the American Coolair Power Tube Fan System costs less to purchase and install initially.

For example, one of our customers, Mr. R. P. Johnson, Manager, Plant Engineering, Fairbanks Weighing Division of Colt Industries in St. Johnsbury, Vermont, realized a \$60,000 savings in just seven months.

“Our 210,000 square foot plant was heated by thirteen Wing Steam heated, wall mounted make-up air units. Each unit supplied 9,700 CFM.

We replaced five of these units with five American Coolair Model No. PT30L make-up air supply fans of 10,200 CFM with 100 feet to 250 feet of tubing.

The use of these fans to replace the steam heated make-up fans has saved us, this heating season (October thru April), 70,131 gallons of No. 6 fuel oil (\$60,097) despite an increase of over 1,000 degree days.”

Sidewall Mount Plan View

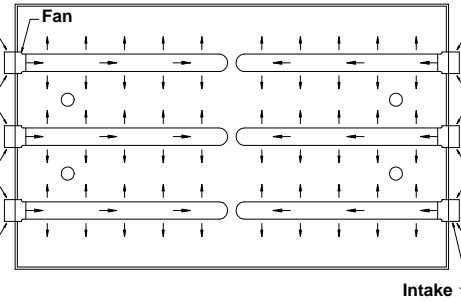

Roof Installation Plan View

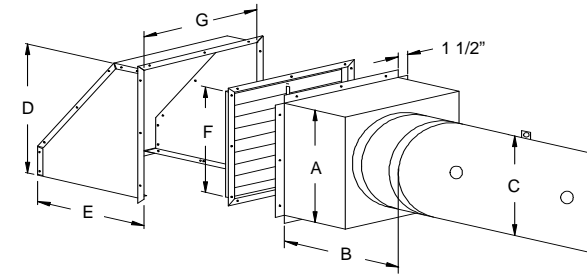
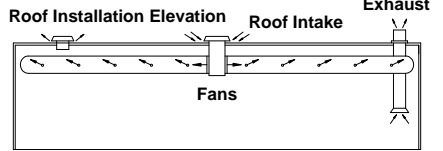
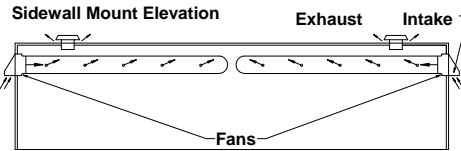
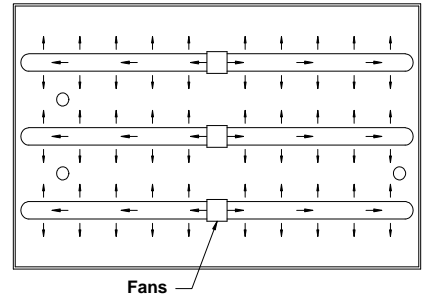

**Dimensions - Wall Fan**

- Dimension A is the O.D. of the housing.
- Dimension B is the length of the housing and orifice.
- Dimension C is the O.D. of the tube.
- Dimension D is the height of the hood, excluding 1-1/2" flange.
- Dimension E is the distance the hood extends from the wall.
- Dimension F is the wall opening size.
- Dimension G is the width of the hood, excluding 1-1/2" flanges.

| Fan Model | Dimensions in Inches |        |    |        |        |        |        |
|-----------|----------------------|--------|----|--------|--------|--------|--------|
|           | A (sq)               | B      | C  | D      | E      | F (sq) | G      |
| PT18      | 24 1/8               | 24 1/4 | 19 | 26 1/2 | 27 1/2 | 22 5/8 | 26 1/2 |
| PT24      | 32 1/4               | 36 1/8 | 25 | 32 1/2 | 33 1/2 | 28 7/8 | 32 1/2 |
| PT30      | 38 1/4               | 37 3/4 | 30 | 38 1/2 | 39 1/2 | 34 7/8 | 38 1/2 |

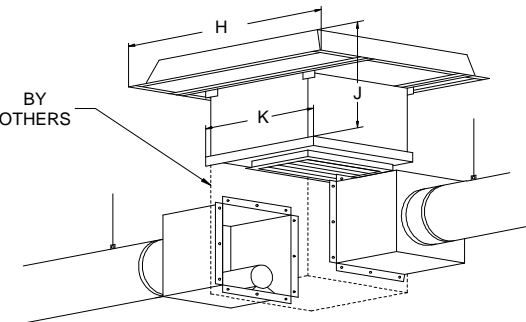

| Roof Intake Model | Dimensions in Inches |        |    | Approx. Ship Wt. |
|-------------------|----------------------|--------|----|------------------|
|                   | H                    | J      | K  |                  |
| PE24GV            | 57                   | 33 3/4 | 38 | 250              |
| PE30GV            | 67                   | 38 1/2 | 44 | 340              |
| PE36GV            | 78                   | 41 3/4 | 50 | 400              |
| PE42GV            | 88                   | 43 7/8 | 56 | 550              |

See selection section for appropriate roof intake model.

**Dimensions - Roof Intake**

- Dimension H is the O.D. of the square hood.
- Dimension J is the overall height above the curb.
- Dimension K is the I.D. of the curb cap flange.

# Performance Ratings

| Item No. | System CFM | Fan Model <sup>1</sup> | Fan Size | Drive  | Motor HP | Fan RPM | Sone Rating <sup>2</sup> | MAX BHP <sup>3</sup> | Approx. Ship Wt. <sup>4</sup> | Max Tube Length (Ft.) |
|----------|------------|------------------------|----------|--------|----------|---------|--------------------------|----------------------|-------------------------------|-----------------------|
| 1        | 3,650      | PT18H                  | 18       | Direct | 1/3      | 1625    | 12                       | .39                  | 130                           | 210                   |
| 2        | 4,850      | PTB24H                 | 24       | Belt   | 1/3      | 784     | 21                       | .46                  | 230                           | 300                   |
| 3        | 6,300      | PTB24K                 |          |        | 3/4      | 1019    | 32                       | .96                  | 250                           | 380                   |
| 4        | 7,600      | PTB30J                 | 30       | Belt   | 1/2      | 643     | 18                       | .64                  | 280                           | 350                   |
| 5        | 10,650     | PTB30L                 |          |        | 1        | 847     | 27                       | 1.30                 | 305                           | 420                   |

- 1 — The first two or three letters of model identify **fan type**. The next two numbers indicate **fan size**, the next letter identifies motor **horsepower**. For example: Model PT18H is Type "PT", 18" size, 1/3 H.P.
- 2 — The sound ratings shown are loudness values in fan sones at 5 ft. (1.5m) in a hemispherical free field calculated per AMCA Standard 301. Values shown are for Installation Type A: free inlet fan sones levels. The sound ratings shown are at system CFM.
- 3 — Maximum brake horsepower (BHP) at system CFM. BHP includes belt drive losses. Because of the cooling the motor receives from the moving air stream, motor loading beyond the nominal nameplate ratings on these American Coolair fans does not overheat the motor and is within NEMA recommended limits and motor service factor. It is not detrimental to the motor and is economically desirable.
- 4 — Approximate shipping weight includes Type PT fan and housing, motorized shutter and weather hood.

ALL SPECIFICATIONS SUBJECT TO CHANGE WITHOUT NOTICE

## Typical Specifications

Power Tube Fans shall be American Coolair Type PT as manufactured by American Coolair Corporation, Jacksonville, Florida; specific models shall be as shown in fan schedule. (Specify for each fan in schedule: tube color and length, phase and voltage; and accessories such as bird guard and face and by-pass dampers.)

## Features

The American Coolair Power Tube Fan Make-Up Air System features a special propeller fan with air straightening vanes.

The tube is constructed of thick woven high-density polyethylene fiber (8 x 10) laminated with poly coating to a thickness of 8 mils. It is 3.8 oz. per square yard material. Burst strength is 118 lbs. per square inch. The material is flame-retardant and complies with NFPA Standard 701. Tubes are available in two colors: blue and white. One end of the tube is factory sealed.

## Selection

Sufficient make-up air should be provided to balance exhaust from general ventilation and process ventilation. Usually several Power Tube Fans will be required, located to distribute air throughout the plant. If additional tempering of make-up air in specific plant areas becomes necessary, unit heaters can be added.

Tube specifications vary for different lengths to be used, so tube length must be stated for each fan.

## Roof Intake Selection

| Recommended Roof Intake Model |             |              |
|-------------------------------|-------------|--------------|
| Fan Model                     | For One Fan | For Two Fans |
| PT18H                         | PE24GV*     | PE24GV       |
| PTB24H                        | PE24GV      | PE30GV       |
| PTB24K                        | PE24GV      | PE30GV       |
| PTB30J                        | PE24GV      | PE36GV       |
| PTB30L                        | PE30GV      | PE42GV       |

**SOUND:** Sound ratings may also be a factor in fan selection. These are provided in Sones. If additional information is needed, contact your nearest American Coolair representative.

## Accessories

**BIRD GUARD:** Guard is made of PVC coated steel wire with 1/2" x 1" spacing. Protects shutter from damage by birds or vandalism. Attaches flat against shutter face giving an unusually attractive appearance. (Model PT24 and PT30 only.)

**FACE AND BY-PASS DAMPERS:** Install between fan and wall opening, allowing mixing of inside plant air with outside air for tempering or 100% recirculation of inside plant air. Complete with modulating damper motor attached. Requires framing and housing by others. Eliminates need for wall shutter.

**SPARK RESISTANT CONSTRUCTION:** For hazardous locations, any Type PT fan can be ordered with a non-ferrous blade assembly (where not normally supplied) and explosion-proof motors. Motors only qualify for Class I Group D and Class II Groups F & G hazards.

## Limited Warranty

In the sale of its products, American Coolair Corporation agrees to correct, by repairs or replacement, any defects in workmanship or material that may develop under proper and normal use during the period of one year from the date of shipment from the factory. Any product or part proving, upon American Coolair's examination, to be defective during limited warranty period will be repaired or replaced, at American Coolair's option, f.o.b. factory, without charge.

Deterioration or wear caused by chemicals, abrasive action or excessive heat shall not constitute defects.

Motors are guaranteed only to the extent of the manufacturer's warranty.

American Coolair's limited warranty does not apply to any of its products or parts that have been subject to accidental damage, misuse by the user, unauthorized modifications, improper installation or electrical wiring, or lack of proper lubrication or other service requirements as established by American Coolair.

Repairs or replacements provided under the above terms shall constitute fulfillment of all American Coolair's obligations with respect to limited warranty.

THE LIMITED WARRANTY STATED HEREIN IS IN LIEU OF ALL OTHER WARRANTIES, EXPRESS, STATUTORY OR IMPLIED, INCLUDING WITHOUT LIMITATION THAT OF MERCHANTABILITY AND FITNESS.

NO LIABILITY FOR REINSTALLATION COST OR FOR ANY SPECIAL, INDIRECT OR CONSEQUENTIAL DAMAGES OF ANY NATURE IS ASSUMED OR SHALL BE IMPOSED UPON AMERICAN COOLAIR.

## WARNING



**DO NOT** INSTALL FAN WITH MOVING PARTS WITHIN 8 FEET OF FLOOR OR GRADE LEVEL WITHOUT A GUARD THAT COMPLIES WITH OSHA REGULATIONS. **DO NOT** USE UNLESS ELECTRICAL WIRING COMPLIES WITH ALL APPLICABLE CODES. **DO NOT** WIRE WITHOUT PROVIDING FOR A POWER SOURCE DISCONNECT AT THE FAN ITSELF. **DO NOT** SERVICE EXCEPT BY A QUALIFIED MAINTENANCE TECHNICIAN AND ONLY AFTER DISCONNECTING THE POWER SOURCE. FAILURE TO OBSERVE THESE PRECAUTIONS CAN RESULT IN SERIOUS INJURY OR DEATH.

## CAUTION



**AMERICAN Coolair®**

REPRESENTED BY:

**AMERICAN COOLAIR CORPORATION**

P.O. BOX 2300 ~ Jacksonville, Florida 32203

Phone: (904) 389-3646

Fax: (904) 387-3449

E-mail: info@coolair.com

Web: americancoolair.com